



Technical comercial data

CU-5.8 T.CU-5.8

Serie CUBETA – Versión 24-05-2023

TECHNICAL DATA:

Material: PP copolymer of first quality, suitable for contact with food according to current regulations.

Colours: White standard. Consult for other colours.

Useful Volume: 5.8 litres
Volume to the edge: 6.2 litres

Weight of the rectangular bucket: 235 g. approx.
Weight of the lid: 75 g. approx.
Weight of the handle: - metal: 37 g. approx.
- plastic: 3 g. approx.
Total Weight: 350 g. approx.



Design surface photographic finish: 105 x 810 mm (height x perimeter).

MEASUREMENTS:

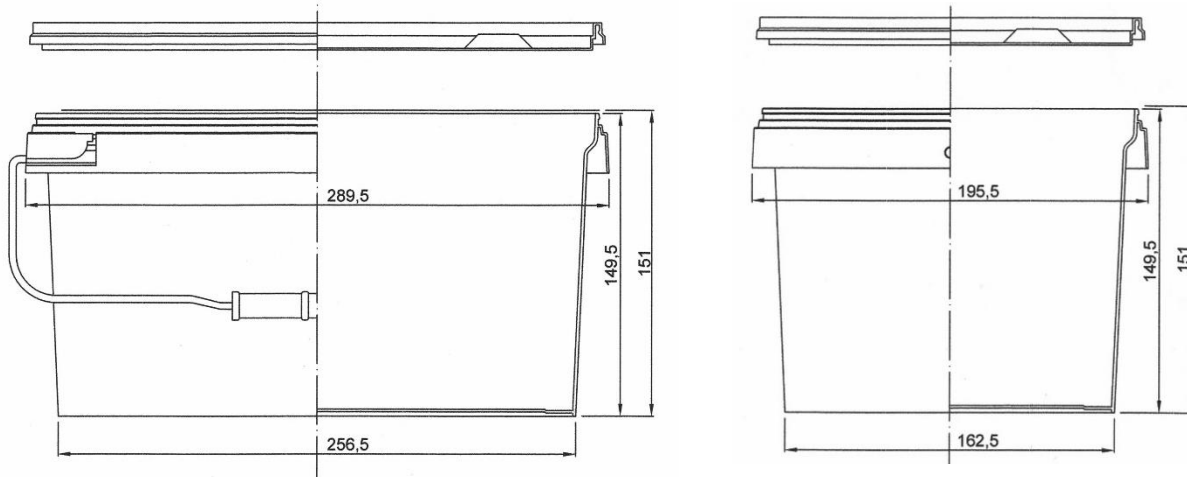

Measurements in millimetres

GROUPING OF TRANSPORT:

Rectangular buckets: 600 rectangular buckets per pallet
Pallet dimensions: 1180 x 1020 x 991 (see drawing)

Lids: 200 lids per box, this serves as a packaging of transportation
Box dimension: 287 x 410 x 810

